

LOW VOLTAGE 2 Megabit (256K x 8) UV EPROM and OTP ROM

- LOW VOLTAGE READ OPERATION:
3V to 5.5V
- ACCESS TIME: 200 and 250ns
- LOW POWER "CMOS" CONSUMPTION:
 - Active Current 15mA
 - Standby Current 20 μ A
- SMALL PACKAGES for SURFACE MOUNTING:
 - Ceramic: LCCC32W, ultra-thin 2.8mm (max) height
 - Plastic: PLCC32 and TSOP32
- PROGRAMMING VOLTAGE: 12.75V
- PROGRAMMING TIMES of AROUND 24sec. (PRESTO II ALGORITHM)
- M27V201 is PROGRAMMABLE as M27C2001 with IDENTICAL SIGNATURE

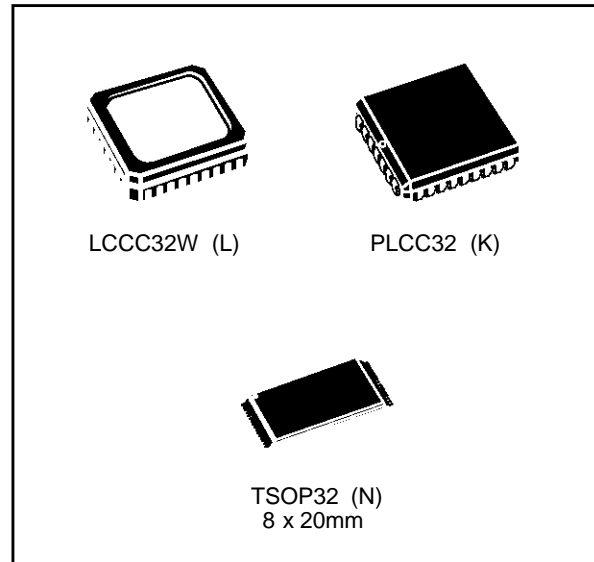

DESCRIPTION

The M27V201 is a low voltage, low power 2 Megabit electrically programmable memory (EPROM), ideally suited for handheld and portable microprocessor systems requiring large programs. It is organized as 262,144 by 8 bits.

The M27V201 operates in the read mode with a supply voltage as low as 3V. The decrease in operating power allows either a reduction of the size of the battery or an increase in the time between battery recharges.

Table 1. Signal Names

A0 - A17	Address Inputs
Q0 - Q7	Data Outputs
\bar{E}	Chip Enable
\bar{G}	Output Enable
\bar{P}	Program
V _{PP}	Program Supply
V _{CC}	Supply Voltage
V _{SS}	Ground

Figure 1. Logic Diagram

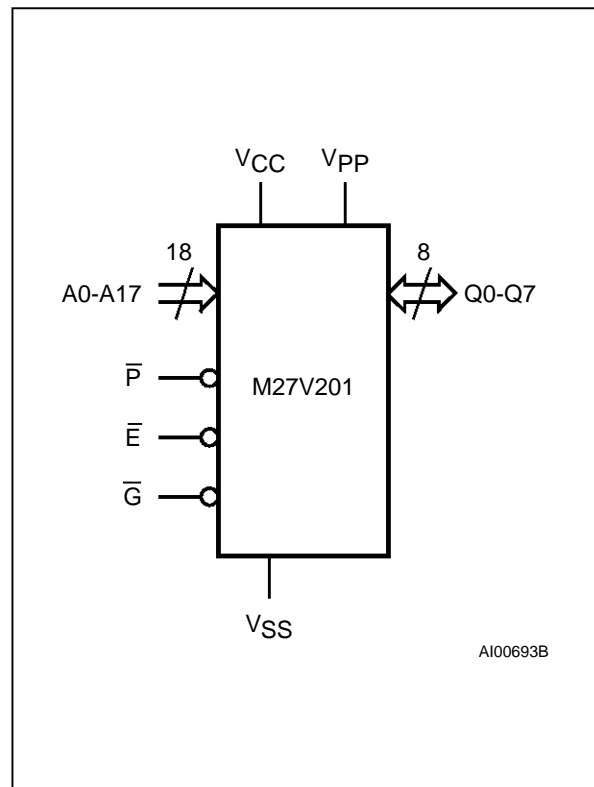

Figure 2A. LCC Pin Connections

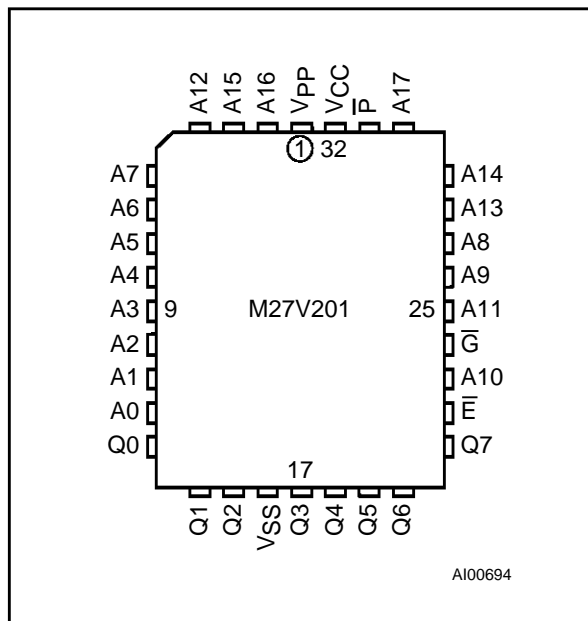

Figure 2B. TSOP Pin Connections

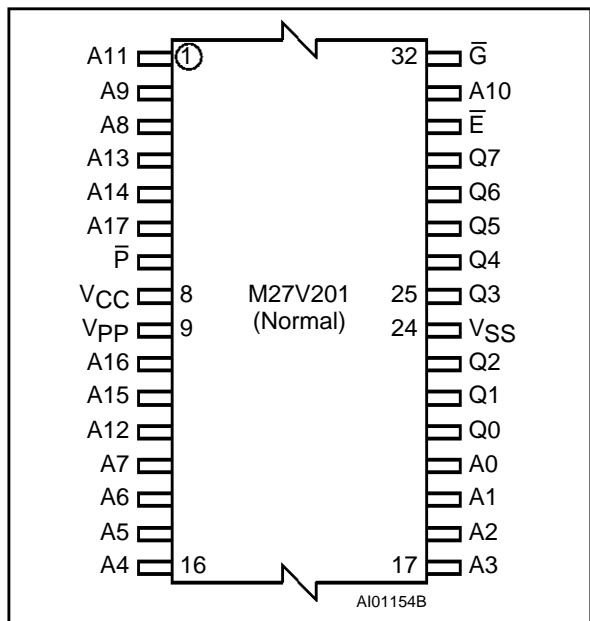

Table 2. Absolute Maximum Ratings ⁽¹⁾

Symbol	Parameter	Value	Unit
T _A	Ambient Operating Temperature	-40 to 125	°C
T _{BIAS}	Temperature Under Bias	-50 to 125	°C
T _{STG}	Storage Temperature	-65 to 150	°C
V _{IO (2)}	Input or Output Voltages (except A9)	-2 to 7	V
V _{CC}	Supply Voltage	-2 to 7	V
V _{A9 (2)}	A9 Voltage	-2 to 13.5	V
V _{PP}	Program Supply Voltage	-2 to 14	V

Notes: 1. Except for the rating "Operating Temperature Range", stresses above those listed in the Table "Absolute Maximum Ratings" may cause permanent damage to the device. These are stress ratings only and operation of the device at these or any other conditions above those indicated in the Operating sections of this specification is not implied. Exposure to Absolute Maximum Rating conditions for extended periods may affect device reliability. Refer also to the SGS-THOMSON SURE Program and other relevant quality documents.

2. Minimum DC voltage on Input or Output is -0.5V with possible undershoot to -2.0V for a period less than 20ns. Maximum DC voltage on Output is V_{CC} +0.5V with possible overshoot to V_{CC} +2V for a period less than 20ns.

DESCRIPTION (cont'd)

The M27V201 can also be operated as a standard 2 Megabit EPROM (similar to M27C2001) with a 5V power supply .

The 32 pin Window, Leadless Chip Carrier package has a transparent lid which allows the user to

expose the chip to ultraviolet light to erase the bit pattern. A new pattern can then be written to the device by following the programming procedure. For applications where the content is programmed only one time and erasure is not required, the M27V201 is offered in both Plastic Leaded Chip Carrier and Plastic thin Small Outline packages.

DEVICE OPERATION

The modes of operation of the M27V201 are listed in the Operating Modes table. A single power supply is required in the read mode. All inputs are TTL levels except for V_{PP} and 12V on A9 for Electronic Signature.

Read Mode

The M27V201 has two control functions, both of which must be logically active in order to obtain data at the outputs. Chip Enable (\bar{E}) is the power control and should be used for device selection. Output Enable (\bar{G}) is the output control and should be used to gate data to the output pins, independent of device selection. Assuming that the addresses are stable, the address access time (t_{AVQV}) is equal to the delay from \bar{E} to output (t_{ELQV}). Data is available at the output after a delay of t_{GLQV} from the falling edge of \bar{G} , assuming that \bar{E} has been low and the addresses have been stable for at least $t_{AVQV} - t_{GLQV}$.

Standby Mode

The M27V201 has a standby mode which reduces the active current from 15mA to 20 μ A with low voltage operation $V_{CC} \leq 3.2V$ (30mA to 100 μ A with a supply of 5.5V), see Read Mode DC Characteristics Table for details. The M27V201 is placed in the standby mode by applying a CMOS high

signal to the \bar{E} input. When in the standby mode, the outputs are in a high impedance state, independent of the \bar{G} input.

Two Line Output Control

Because EPROMs are usually used in larger memory arrays, this product features a 2 line control function which accommodates the use of multiple memory connection. The two line control function allows :

- the lowest possible memory power dissipation,
- complete assurance that output bus contention will not occur.

For the most efficient use of these two control lines, \bar{E} should be decoded and used as the primary device selecting function, while \bar{G} should be made a common connection to all devices in the array and connected to the \overline{READ} line from the system control bus. This ensures that all deselected memory devices are in their low power standby mode and that the output pins are only active when data is required from a particular memory device.

System Considerations

The power switching characteristics of Advanced CMOS EPROMs require careful decoupling of the devices. The supply current, I_{CC} , has three segments that are of interest to the system designer:

Table 3. Operating Modes

Mode	\bar{E}	\bar{G}	\bar{P}	A9	V_{PP}	Q0 - Q7
Read	V_{IL}	V_{IL}	X	X	V_{CC} or V_{SS}	Data Out
Output Disable	V_{IL}	V_{IH}	X	X	V_{CC} or V_{SS}	Hi-Z
Program	V_{IL}	V_{IH}	V_{IL} Pulse	X	V_{PP}	Data In
Verify	V_{IL}	V_{IL}	V_{IH}	X	V_{PP}	Data Out
Program Inhibit	V_{IH}	X	X	X	V_{PP}	Hi-Z
Standby	V_{IH}	X	X	X	V_{CC} or V_{SS}	Hi-Z
Electronic Signature	V_{IL}	V_{IL}	V_{IH}	V_{ID}	V_{CC}	Codes

Note: X = V_{IH} or V_{IL} , $V_{ID} = 12V \pm 0.5V$

Table 4. Electronic Signature

Identifier	A0	Q7	Q6	Q5	Q4	Q3	Q2	Q1	Q0	Hex Data
Manufacturer's Code	V_{IL}	0	0	1	0	0	0	0	0	20h
Device Code	V_{IH}	0	1	1	0	0	0	0	1	61h

AC MEASUREMENT CONDITIONS

Input Rise and Fall Times $\leq 20\text{ns}$
 Input Pulse Voltages 0.4 to 2.4V
 Input and Output Timing Ref. Voltages 0.8 to 2.0V

Note that Output Hi-Z is defined as the point where data is no longer driven.

Figure 3. AC Testing Input Output Waveforms

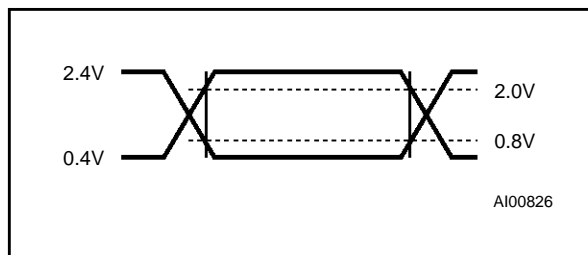

Figure 4. AC Testing Load Circuit

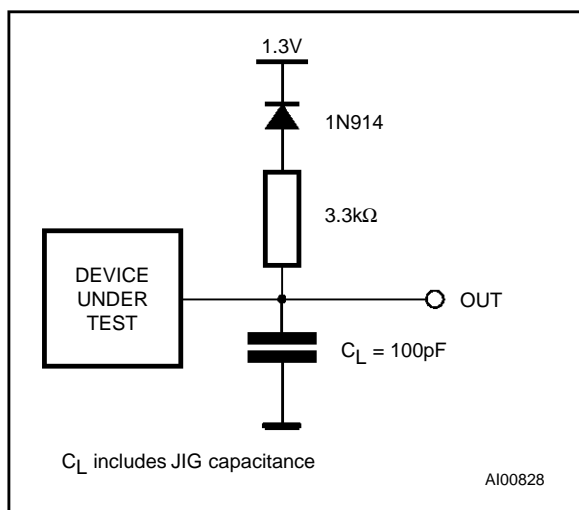

Table 5. Capacitance⁽¹⁾ ($T_A = 25\text{ }^\circ\text{C}$, $f = 1\text{ MHz}$)

Symbol	Parameter	Test Condition	Min	Max	Unit
C_{IN}	Input Capacitance	$V_{IN} = 0V$		6	pF
C_{OUT}	Output Capacitance	$V_{OUT} = 0V$		12	pF

Note: 1. Sampled only, not 100% tested.

Table 6. Read Mode DC Characteristics⁽¹⁾

($T_A = 0\text{ to }70\text{ }^\circ\text{C}$ or $-40\text{ to }85\text{ }^\circ\text{C}$; $V_{CC} = 3V\text{ to }5.5V$ unless specified; $V_{PP} = V_{CC}$)

Symbol	Parameter	Test Condition	Min	Max	Unit
I_{LI}	Input Leakage Current	$0V \leq V_{IN} \leq V_{CC}$		± 10	μA
I_{LO}	Output Leakage Current	$0V \leq V_{OUT} \leq V_{CC}$		± 10	μA
I_{CC}	Supply Current	$\bar{E} = V_{IL}, \bar{G} = V_{IL}, I_{OUT} = 0mA, f = 5MHz, V_{CC} \leq 3.2V$		15	mA
		$\bar{E} = V_{IL}, \bar{G} = V_{IL}, I_{OUT} = 0mA, f = 5MHz, V_{CC} = 5.5V$		30	mA
I_{CC1}	Supply Current (Standby) TTL	$\bar{E} = V_{IH}$		1	mA
I_{CC2}	Supply Current (Standby) CMOS	$\bar{E} > V_{CC} - 0.2V, V_{CC} \leq 3.2V$		20	μA
		$\bar{E} > V_{CC} - 0.2V, V_{CC} = 5.5V$		100	μA
I_{PP}	Program Current	$V_{PP} = V_{CC}$		10	μA
V_{IL}	Input Low Voltage		-0.3	0.8	V
$V_{IH}^{(2)}$	Input High Voltage		2	$V_{CC} + 1$	V
V_{OL}	Output Low Voltage	$I_{OL} = 2.1mA$		0.4	V
V_{OH}	Output High Voltage TTL	$I_{OH} = -400\mu A$	2.4		V
	Output High Voltage CMOS	$I_{OH} = -100\mu A$	$V_{CC} - 0.7V$		V

Notes: 1. V_{CC} must be applied simultaneously with or before V_{PP} and removed simultaneously or after V_{PP} .
 2. Maximum DC voltage on Output is $V_{CC} + 0.5V$.

Table 7. Read Mode AC Characteristics⁽¹⁾(T_A = 0 to 70 °C or -40 to 85 °C; V_{CC} = 3V to 5.5V unless specified; V_{PP} = V_{CC})

Symbol	Alt	Parameter	Test Condition	M27V201				Unit
				-200		-250		
				Min	Max	Min	Max	
t _{AVQV}	t _{ACC}	Address Valid to Output Valid	$\bar{E} = V_{IL}, \bar{G} = V_{IL}$		200		250	ns
t _{ELQV}	t _{CE}	Chip Enable Low to Output Valid	$\bar{G} = V_{IL}$		200		250	ns
t _{GLQV}	t _{OE}	Output Enable Low to Output Valid	$\bar{E} = V_{IL}$		100		120	ns
t _{EHQZ} ⁽²⁾	t _{DF}	Chip Enable High to Output Hi-Z	$\bar{G} = V_{IL}$	0	80	0	80	ns
t _{GHQZ} ⁽²⁾	t _{DF}	Output Enable High to Output Hi-Z	$\bar{E} = V_{IL}$	0	80	0	80	ns
t _{AXQX}	t _{OH}	Address Transition to Output Transition	$\bar{E} = V_{IL}, \bar{G} = V_{IL}$	0		0		ns

Notes: 1. V_{CC} must be applied simultaneously with or before V_{PP} and removed simultaneously or after V_{PP}.
 2. Sampled only, not 100% tested.

Figure 5. Read Mode AC Waveforms

Table 8. Programming Mode DC Characteristics ⁽¹⁾
 ($T_A = 25\text{ }^\circ\text{C}$; $V_{CC} = 6.25\text{V} \pm 0.25\text{V}$; $V_{PP} = 12.75\text{V} \pm 0.25\text{V}$)

Symbol	Parameter	Test Condition	Min	Max	Unit
I_{LI}	Input Leakage Current	$V_{IL} \leq V_{IN} \leq V_{IH}$		± 10	μA
I_{CC}	Supply Current			50	mA
I_{PP}	Program Current	$\bar{E} = V_{IL}$		50	mA
V_{IL}	Input Low Voltage		-0.3	0.8	V
V_{IH}	Input High Voltage		2	$V_{CC} + 0.5$	V
V_{OL}	Output Low Voltage	$I_{OL} = 2.1\text{mA}$		0.4	V
V_{OH}	Output High Voltage TTL	$I_{OH} = -400\mu\text{A}$	2.4		V
V_{ID}	A9 Voltage		11.5	12.5	V

Note: 1. V_{CC} must be applied simultaneously with or before V_{PP} and removed simultaneously or after V_{PP} .

Table 9. Programming Mode AC Characteristics ⁽¹⁾
 ($T_A = 25\text{ }^\circ\text{C}$; $V_{CC} = 6.25\text{V} \pm 0.25\text{V}$; $V_{PP} = 12.75\text{V} \pm 0.25\text{V}$)

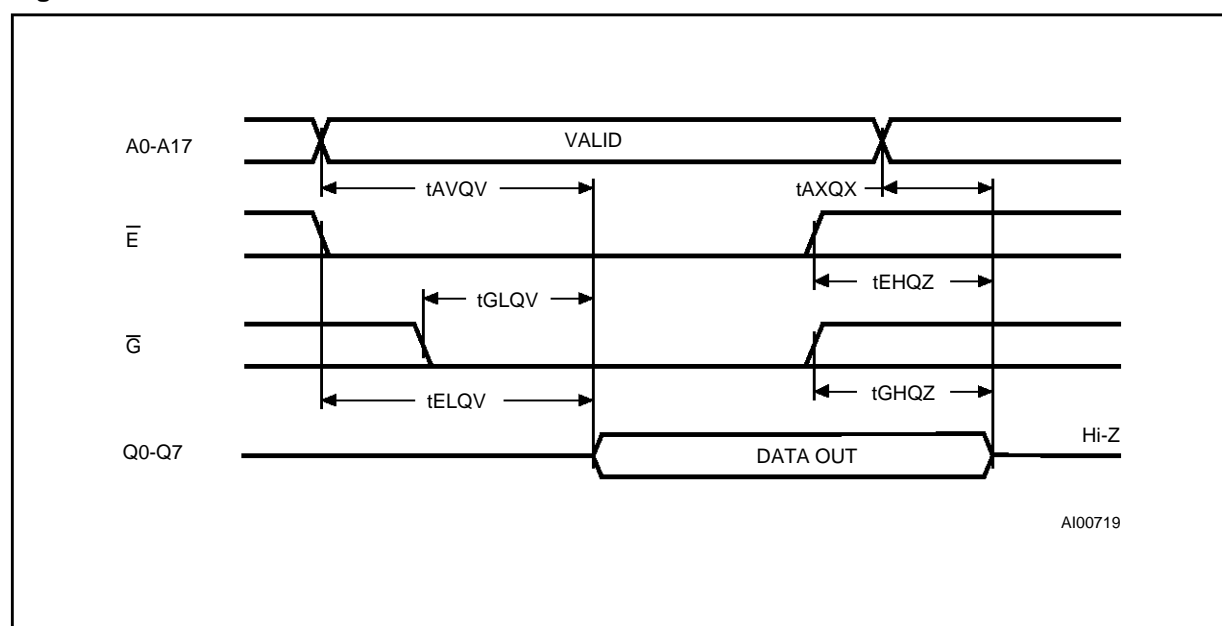
Symbol	Alt	Parameter	Test Condition	Min	Max	Unit
t_{AVPL}	t_{AS}	Address Valid to Program Low		2		μs
t_{QVPL}	t_{DS}	Input Valid to Program Low		2		μs
t_{VPHPL}	t_{VPS}	V_{PP} High to Program Low		2		μs
t_{VCHPL}	t_{VCS}	V_{CC} High to Program Low		2		μs
t_{ELPL}	t_{CES}	Chip Enable Low to Program Low		2		μs
t_{PLPH}	t_{PW}	Program Pulse Width		95	105	μs
t_{PHQX}	t_{DH}	Program High to Input Transition		2		μs
t_{QXGL}	t_{OES}	Input Transition to Output Enable Low		2		μs
t_{GLQV}	t_{OE}	Output Enable Low to Output Valid			100	ns
$t_{GHQZ}^{(2)}$	t_{DFP}	Output Enable High to Output Hi-Z		0	130	ns
t_{GHAX}	t_{AH}	Output Enable High to Address Transition		0		ns

Notes: 1. V_{CC} must be applied simultaneously with or before V_{PP} and removed simultaneously or after V_{PP} .
 2. Sampled only, not 100% tested.

Figure 6. Programming and Verify Modes AC Waveforms

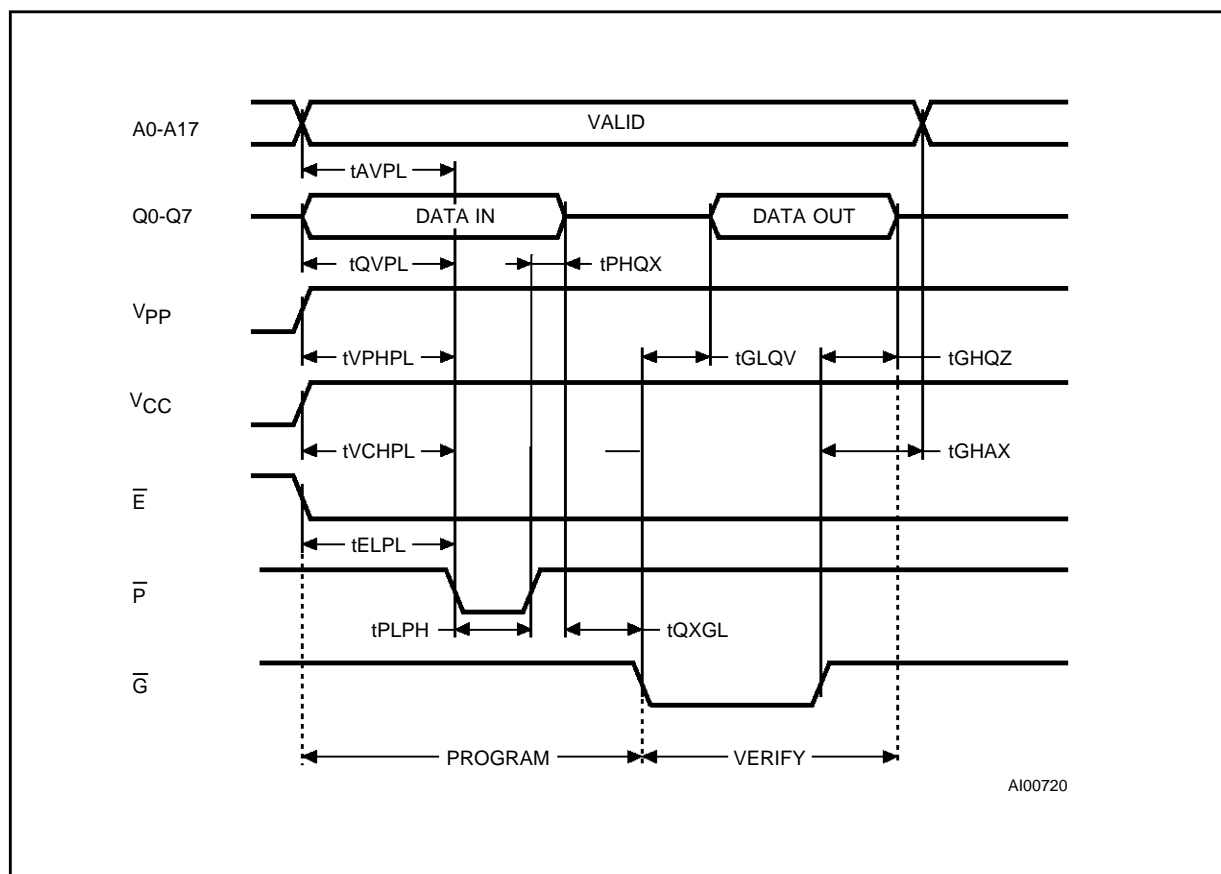

AI00720

DEVICE OPERATION (cont'd)

the standby current level, the active current level, and transient current peaks that are produced by the falling and rising edges of \bar{E} . The magnitude of the transient current peaks is dependent on the capacitive and inductive loading of the device at the output.

The associated transient voltage peaks can be suppressed by complying with the two line output control and by properly selected decoupling capacitors. It is recommended that a 0.1 μ F ceramic capacitor be used on every device between V_{CC} and V_{SS}. This should be a high frequency capacitor of low inherent inductance and should be placed as close to the device as possible. In addition, a 4.7 μ F bulk electrolytic capacitor should be used between V_{CC} and V_{SS} for every eight devices. The bulk capacitor should be located near the power supply connection point. The purpose of the bulk capacitor is to overcome the voltage drop caused by the inductive effects of PCB traces.

Programming

The M27V201 has been designed to be fully compatible with the M27C2001. As a result the M27V201 can be programmed as the M27C2001 on the same programmers applying 12.75V on V_{PP} and 6.25V on V_{CC}. The M27V201 has the same electronic signature and uses the same PRESTO II algorithm.

When delivered (and after each erasure for UV EPROM), all bits of the M27V201 are in the "1" state. Data is introduced by selectively programming "0s" into the desired bit locations. Although only "0s" will be programmed, both "1s" and "0s" can be present in the data word. The only way to change a "0" to a "1" is by die exposure to ultraviolet light (UV EPROM). The M27V201 is in the programming mode when V_{PP} input is at 12.75V, and \bar{E} and \bar{P} are at TTL-low. The data to be programmed is applied 8 bits in parallel to the data output pins. The levels required for the address and data inputs are TTL. V_{CC} is specified to be 6.25V \pm 0.25V.

Figure 7. Programming Flowchart

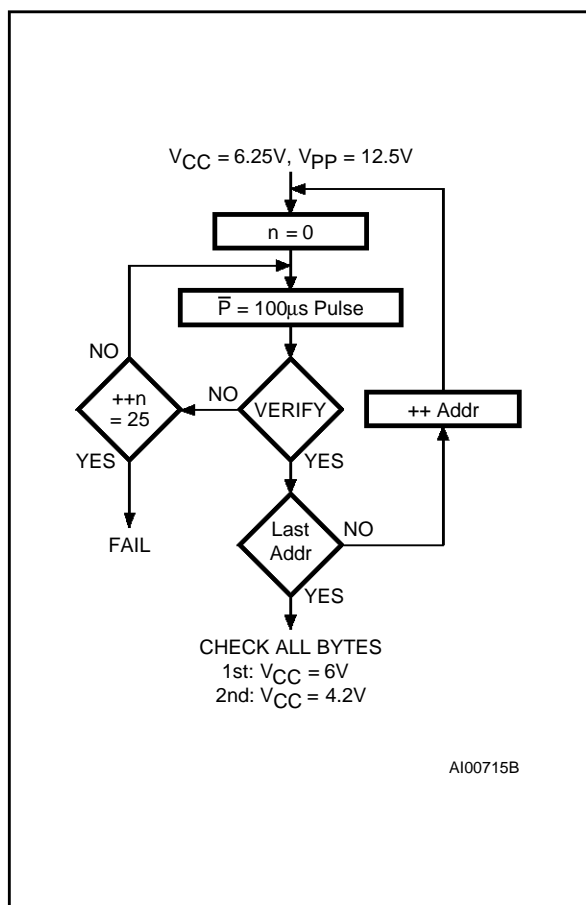

PRESTO II Programming Algorithm

PRESTO II Programming Algorithm allows the whole array to be programmed, with a guaranteed margin, in a typical time of 26.5 seconds. Programming with PRESTO II involves in applying a sequence of 100µs program pulses to each byte until a correct verify occurs. During programming and verify operation, a MARGIN MODE circuit is automatically activated in order to guarantee that each cell is programmed with enough margin. No over-program pulse is applied since the verify in MARGIN MODE provides necessary margin to each programmed cell.

Program Inhibit

Programming of multiple M27V201s in parallel with different data is also easily accomplished. Except for \bar{E} , all like inputs including \bar{G} of the parallel M27V201 may be common. A TTL low level pulse applied to a M27V201's \bar{E} input, with \bar{P} low and V_{PP} at 12.75V, will program that M27V201. A high level \bar{E} input inhibits the other M27V201s from being programmed.

Program Verify

A verify (read) should be performed on the programmed bits to determine that they were correctly programmed. The verify is accomplished with \bar{E} and \bar{G} at V_{IL} , \bar{P} at V_{IH} , V_{PP} at 12.75V and V_{CC} at 6.25V.

Electronic Signature

The Electronic Signature mode allows the reading out of a binary code from an EPROM that will identify its manufacturer and type. This mode is intended for use by programming equipment to automatically match the device to be programmed with its corresponding programming algorithm. This mode is functional in the $25^{\circ}\text{C} \pm 5^{\circ}\text{C}$ ambient temperature range that is required when programming the M27V201. To activate this mode, the programming equipment must force 11.5V to 12.5V on address line A9 of the M27V201, with $V_{PP} = V_{CC} = 5\text{V}$. Two identifier bytes may then be sequenced from the device outputs by toggling address line A0 from V_{IL} to V_{IH} . All other address lines must be held at V_{IL} during Electronic Signature mode.

Byte 0 ($A_0=V_{IL}$) represents the manufacturer code and byte 1 ($A_0=V_{IH}$) the device identifier code. For the SGS-THOMSON M27V201, these two identifier bytes are given in Table 4 and can be read-out on outputs Q0 to Q7. Note that the M27V201 and M27C2001 have the same identifier bytes.

ERASURE OPERATION (applies to UV EPROM)

The erasure characteristics of the M27V201 is such that erasure begins when the cells are exposed to light with wavelengths shorter than approximately 4000Å. It should be noted that sunlight and some type of fluorescent lamps have wavelengths in the 3000-4000Å range. Research shows that constant exposure to room level fluorescent lighting could erase a typical M27V201 in about 3 years, while it would take approximately 1 week to cause erasure when exposed to direct sunlight. If the M27V201 is to be exposed to these types of lighting conditions for extended periods of time, it is suggested that opaque labels be put over the M27V201 window to prevent unintentional erasure. The recommended erasure procedure for the M27V201 is exposure to short wave ultraviolet light which has a wavelength of 2537Å. The integrated dose (i.e. UV intensity x exposure time) for erasure should be a minimum of 15 W-sec/cm². The erasure time with this dosage is approximately 15 to 20 minutes using an ultraviolet lamp with 12000 uW/cm² power rating. The M27V201 should be placed within 2.5 cm (1 inch) of the lamp tubes during the erasure. Some lamps have a filter on their tubes which should be removed before erasure.

ORDERING INFORMATION SCHEME

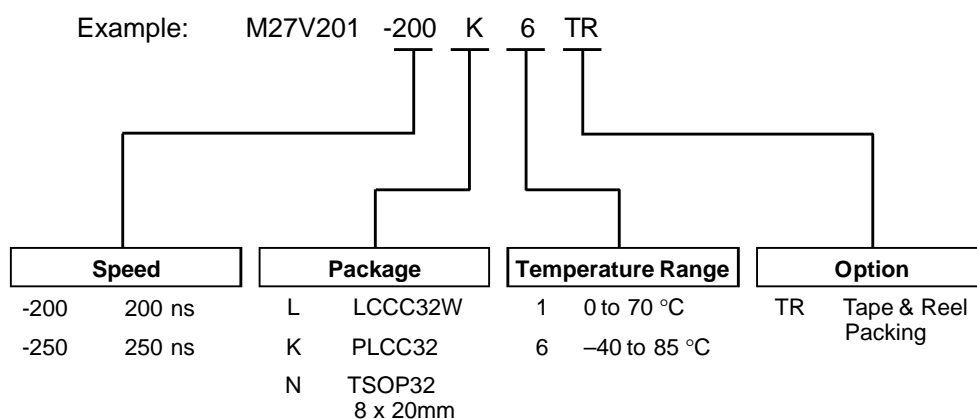

For a list of available options (Speed, Package, Temperature Range, etc...) refer to the current Memory Shortform catalogue.

For further information on any aspect of this device, please contact SGS-THOMSON Sales Office nearest to you.

LCCC32W - 32 lead Leadless Ceramic Chip Carrier, square window

Symb	mm			inches		
	Typ	Min	Max	Typ	Min	Max
A			2.28			0.090
B		0.51	0.71		0.020	0.028
D		11.23	11.63		0.442	0.458
E		13.72	14.22		0.540	0.560
e	1.27	–	–	0.050	–	–
e1		0.39	–		0.015	–
e2	7.62	–	–	0.300	–	–
e3	10.16	–	–	0.400	–	–
h	1.02	–	–	0.040	–	–
j	0.51	–	–	0.020	–	–
L		1.14	1.40		0.045	0.055
L1		1.96	2.36		0.077	0.093
K		10.50	10.80		0.413	0.425
K1		8.03	8.23		0.316	0.324
N		32			32	

LCCC32W

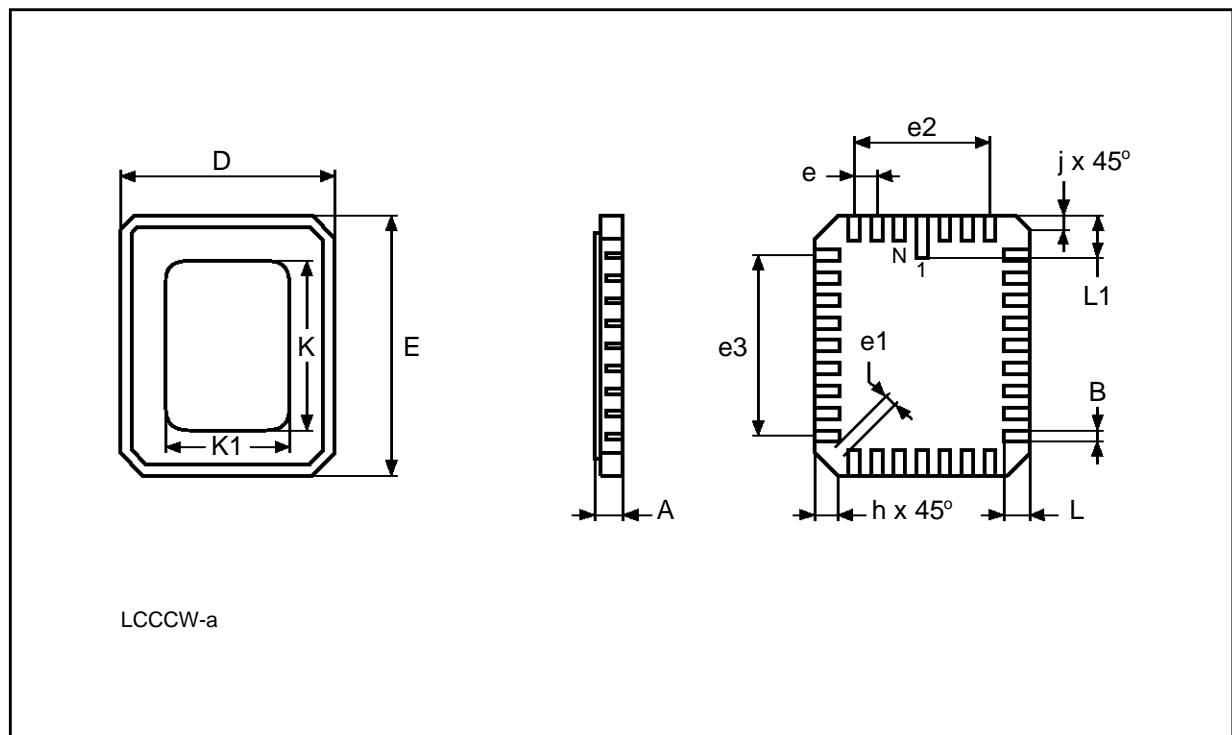

Drawing is not to scale

PLCC32 - 32 lead Plastic Leaded Chip Carrier, rectangular

Symb	mm			inches		
	Typ	Min	Max	Typ	Min	Max
A		2.54	3.56		0.100	0.140
A1		1.52	2.41		0.060	0.095
B		0.33	0.53		0.013	0.021
B1		0.66	0.81		0.026	0.032
D		12.32	12.57		0.485	0.495
D1		11.35	11.56		0.447	0.455
D2		9.91	10.92		0.390	0.430
E		14.86	15.11		0.585	0.595
E1		13.89	14.10		0.547	0.555
E2		12.45	13.46		0.490	0.530
e	1.27	–	–	0.050	–	–
N		32			32	
Nd		7			7	
Ne		9			9	
CP			0.10			0.004

PLCC32

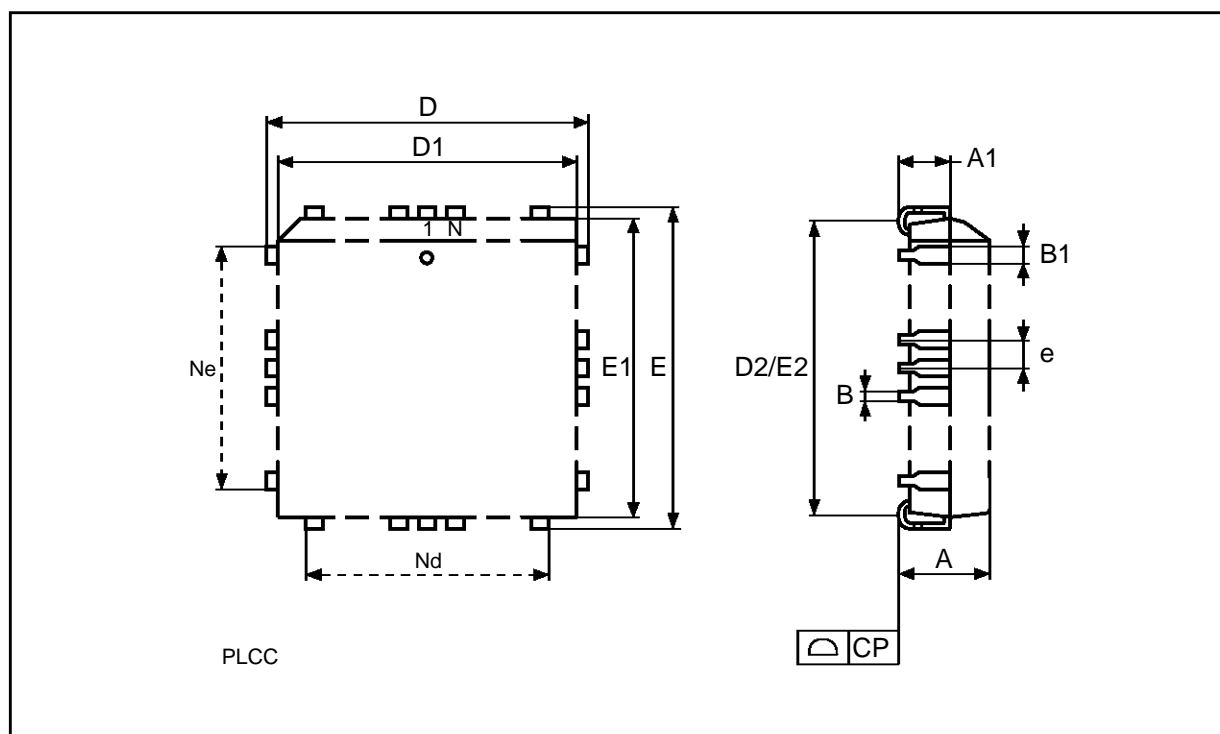

Drawing is not to scale

TSOP32 - 32 lead Plastic Thin Small Outline, 8 x 20mm

Symb	mm			inches		
	Typ	Min	Max	Typ	Min	Max
A			1.20			0.047
A1		0.05	0.17		0.002	0.006
A2		0.95	1.50		0.037	0.059
B		0.15	0.27		0.006	0.011
C		0.10	0.21		0.004	0.008
D		19.80	20.20		0.780	0.795
D1		18.30	18.50		0.720	0.728
E		7.90	8.10		0.311	0.319
e	0.50	–	–	0.020	–	–
L		0.50	0.70		0.020	0.028
α		0°	5°		0°	5°
N	32			32		
CP			0.10			0.004

TSOP32

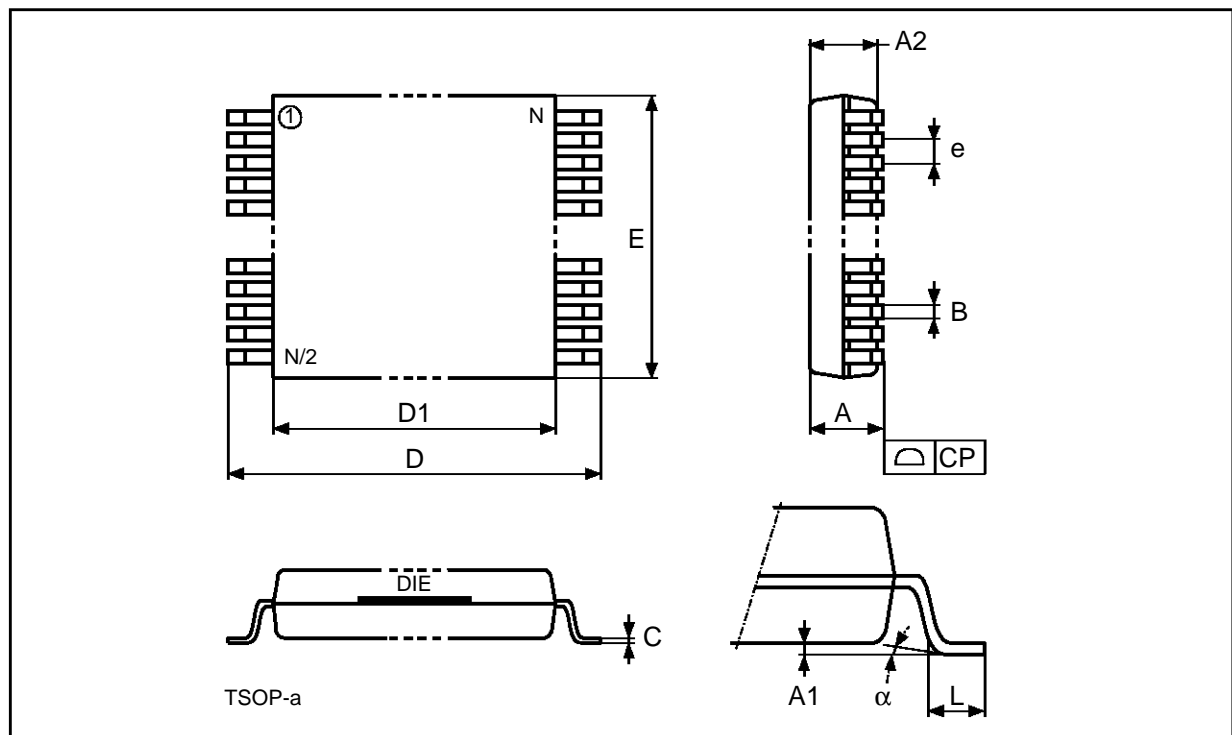

Drawing is not to scale

Information furnished is believed to be accurate and reliable. However, SGS-THOMSON Microelectronics assumes no responsibility for the consequences of use of such information nor for any infringement of patents or other rights of third parties which may result from its use. No license is granted by implication or otherwise under any patent or patent rights of SGS-THOMSON Microelectronics. Specifications mentioned in this publication are subject to change without notice. This publication supersedes and replaces all information previously supplied. SGS-THOMSON Microelectronics products are not authorized for use as critical components in life support devices or systems without express written approval of SGS-THOMSON Microelectronics.

© 1995 SGS-THOMSON Microelectronics - All Rights Reserved

SGS-THOMSON Microelectronics GROUP OF COMPANIES
Australia - Brazil - China - France - Germany - Hong Kong - Italy - Japan - Korea - Malaysia - Malta - Morocco - The Netherlands -
Singapore - Spain - Sweden - Switzerland - Taiwan - Thailand - United Kingdom - U.S.A.